

### Volkmann Series 8000 Typical Connection Diagram

### SPINDEL AV Series Cross Reference Connection Diagram

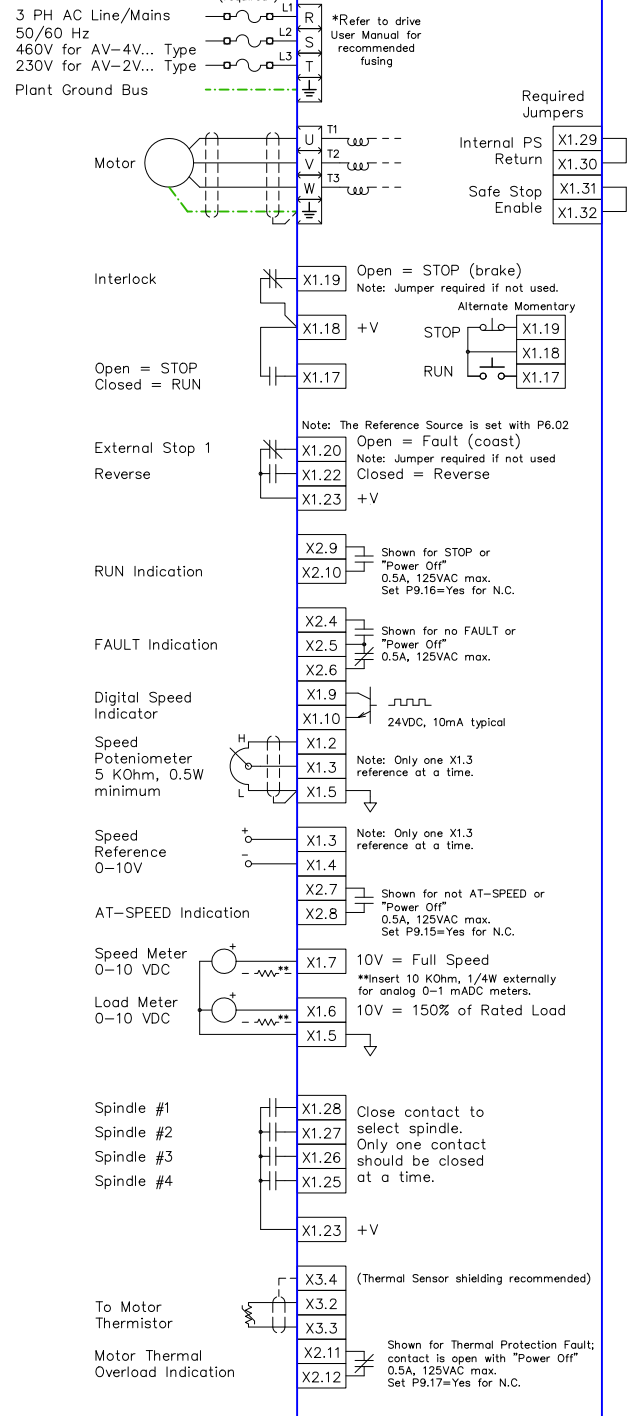
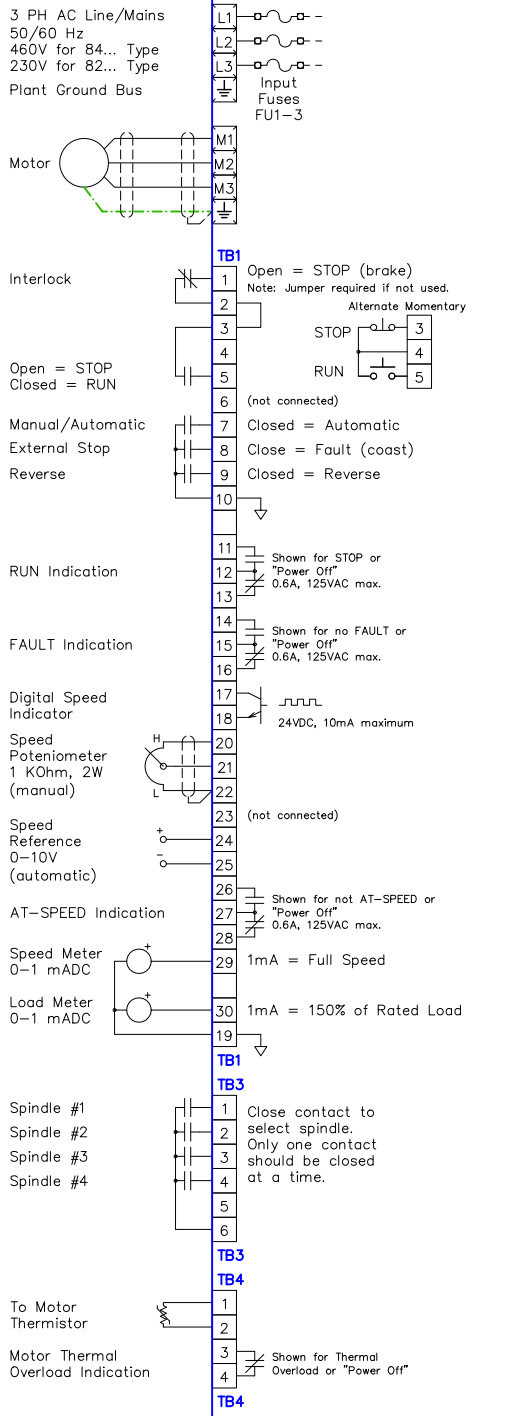

Note: There are additional functions on the following terminals not shown:  
 X1.8: Analog Input #2  
 X1.11-16: High Speed Solid State Outputs (5)  
 X1.21: Digital Input #4 (Reset)  
 X1.24: Digital Input #6 (Motor Select 2^4)

**Programming Note:**

SPINDEL AV Series Drives are highly programmable. The terminal functions shown in this cross reference assume **all drive parameters have been set to their default value** (via the "Control Panel" Menu) and then the following parameters are programmed as indicated:

- P4.01, Acceleration Time = 10.0 (for all motors used)
- P4.02, Deceleration Time = 10.0 (for all motors used)
- P6.08, External Stop 1 Type Select = Coast to Stop
- P7.02, Motor Selection Source = X1 Motor Code
- P7.03, X1 Motor Select Coding Type = Single Contact
- P8.02, Digital Input X1.19 (DI2) Select = Stop/Interlock
- P8.03, Digital Input X1.20 (DI3) Select = External Stop 1
- P8.05, Digital Input X1.22 (DI5) Select = Reversing
- P9.13, Relay X2.11-12 (#3) Select = Thermal Protection Fault

In addition to the above, the motor parameters (Groups 1 and 2) must also be programmed.

		SPINDEL Electronics 4517 Broadmoor Avenue SE Grand Rapids, MI 49512 TEL +1 616 554 2200 FAX +1 616 554 2033	
Date:	9 May 13	Title:	Volkmann Series 8000-SPINDEL AV Series Connection Cross Reference
Drawn By:	KLG	Size:	A*
Date:	11 Sep 15	Scale:	1:1.575
Checked By:	OMM	Drawing No.:	81135-0
		Sheet: 1 of 1	